

E

Calderas de gas

Instrucciones de Instalación,
Montaje y Funcionamiento
para el **INSTALADOR** Página 11

GB

Gas Boilers

Installation, Assembly and
Operating Instructions
for the **INSTALLER** Page 13

F

Chaudières à gaz

Instructions d'Installation,
de Montage et de Fonctionnement,
pour l'**INSTALLATEUR** Page 15

D

Gasheizkessel

Installations-, Montage-
und Betriebsanleitung
für den **INSTALLATEUR** Seite 17

I

Caldaie a gas

Istruzioni d'Installazione,
Montaggio e Funzionamento
per l'**INSTALLATORE** Pagina 20

P

Caldeiras a gás

Instruções de Instalação,
Montagem e Funcionamento
para o **INSTALADOR** Página 22



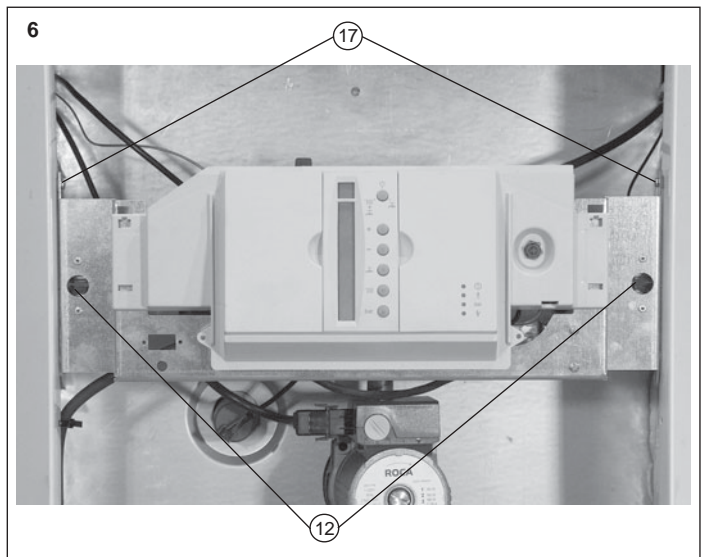
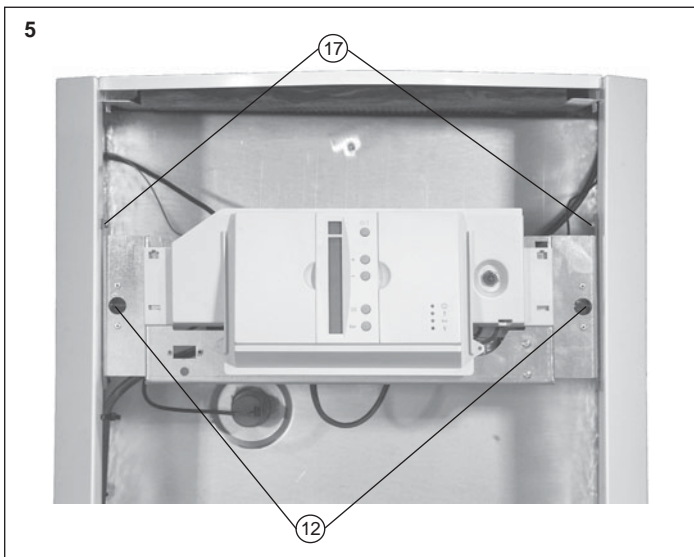
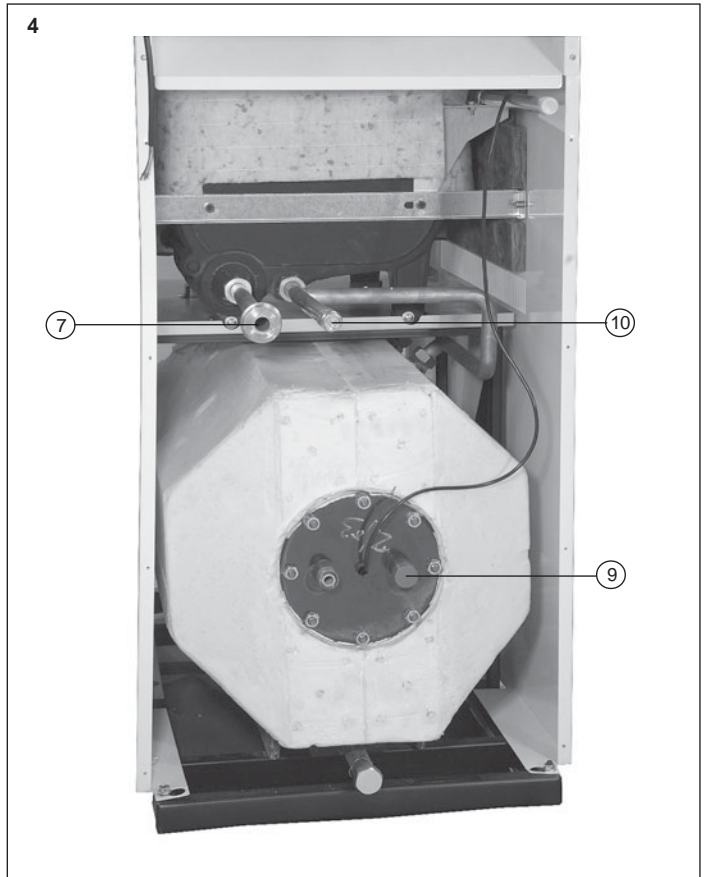
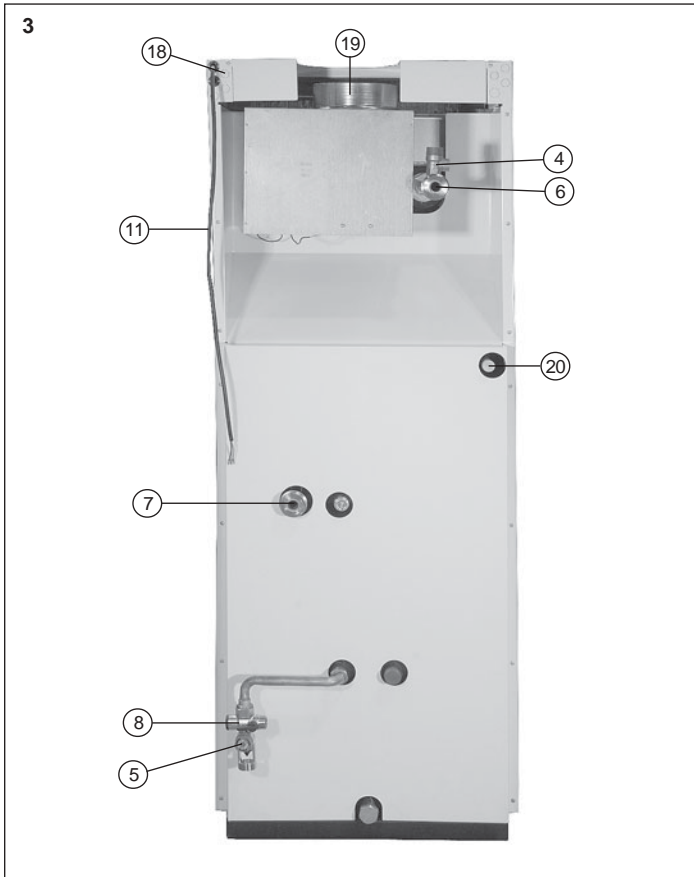
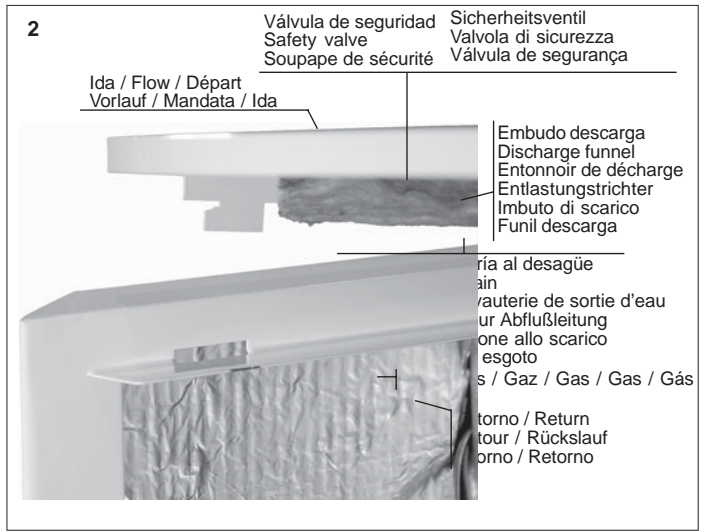
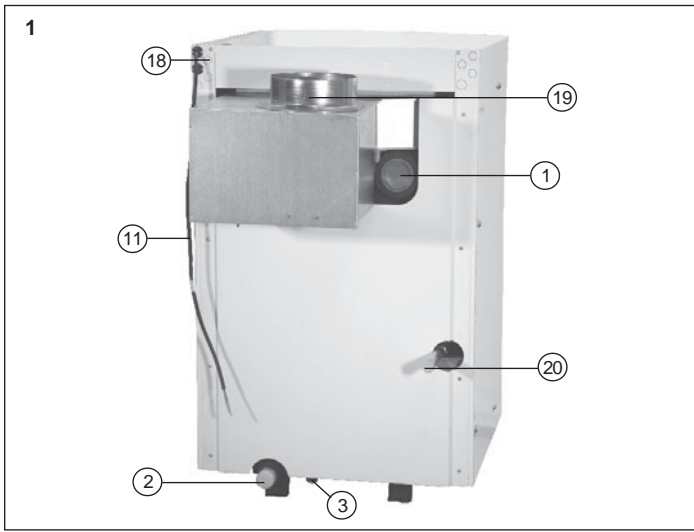

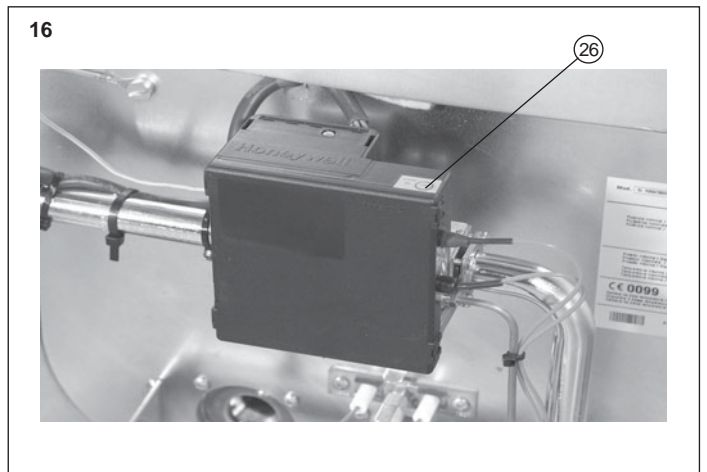
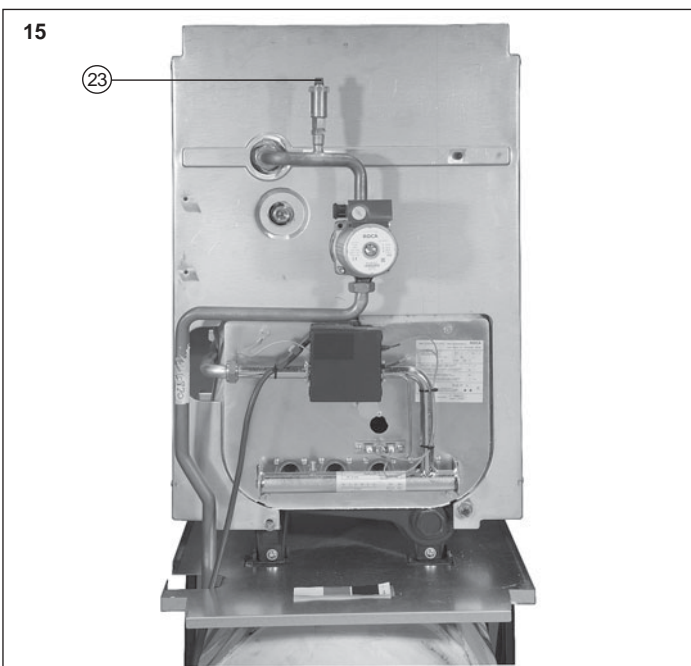
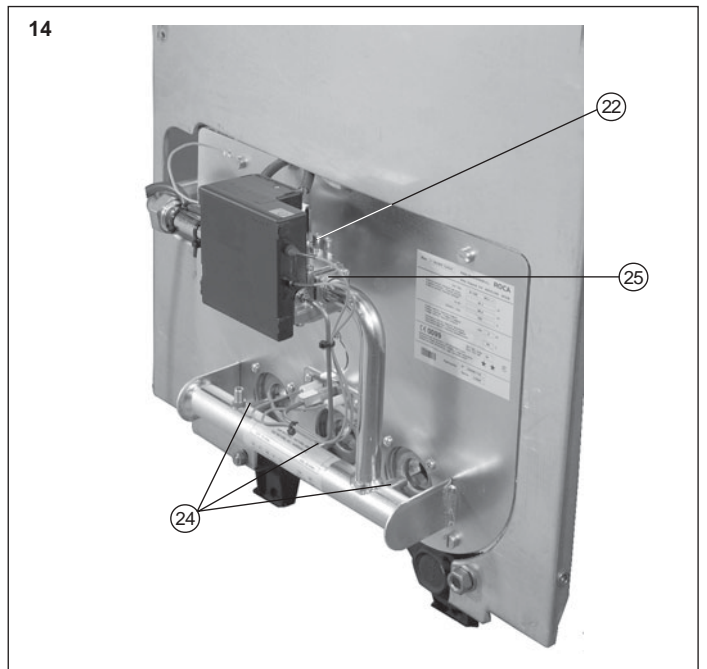
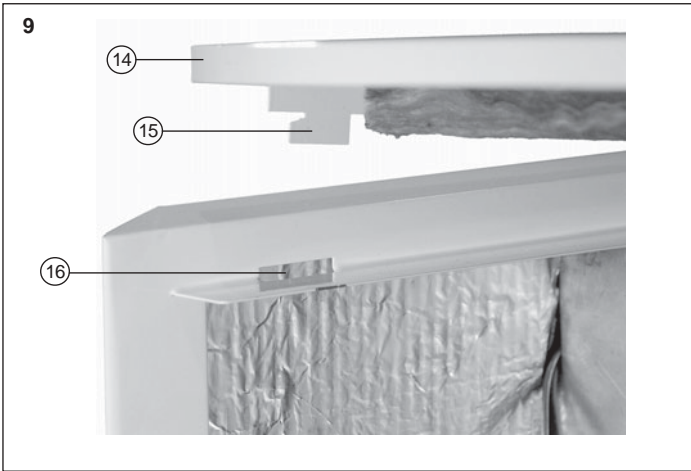
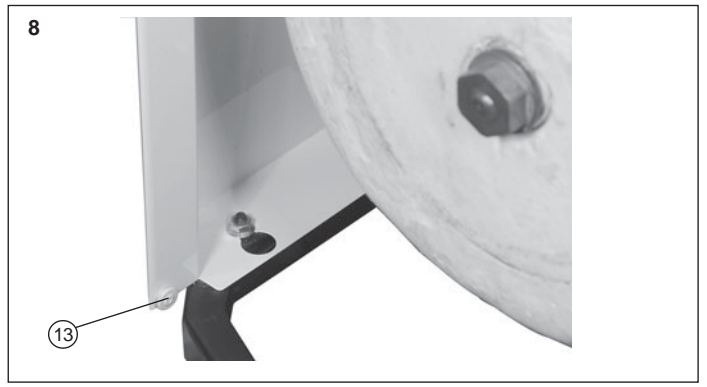
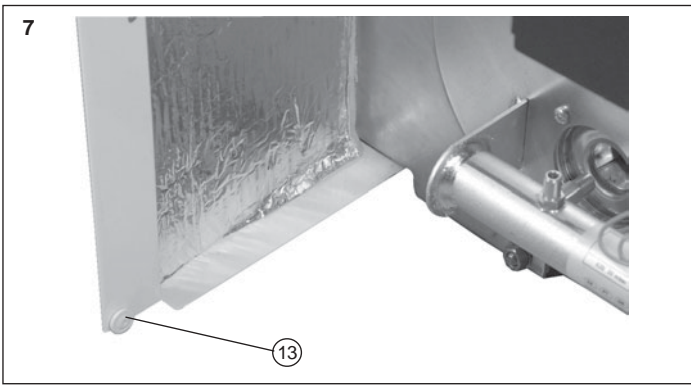

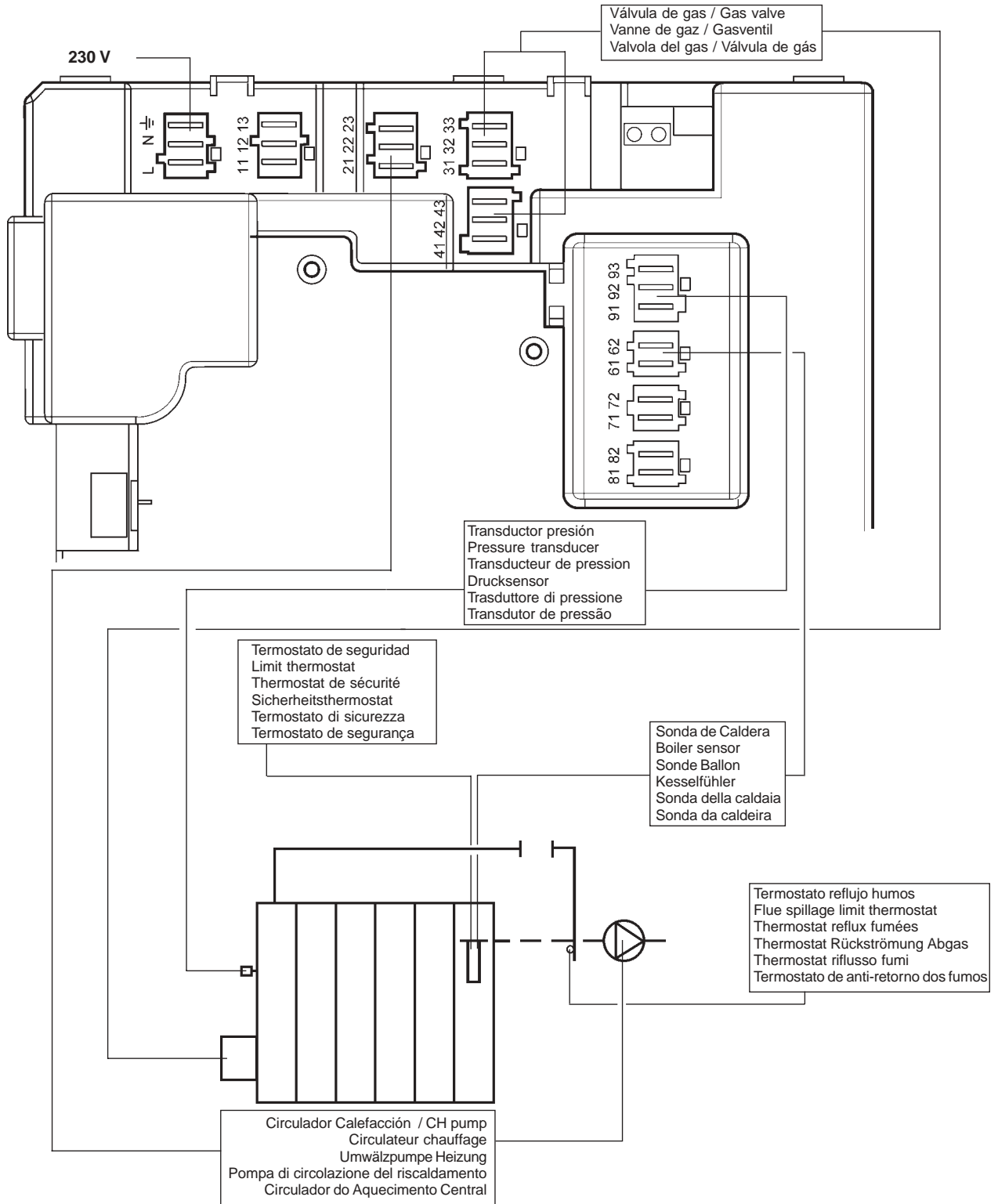

G 100

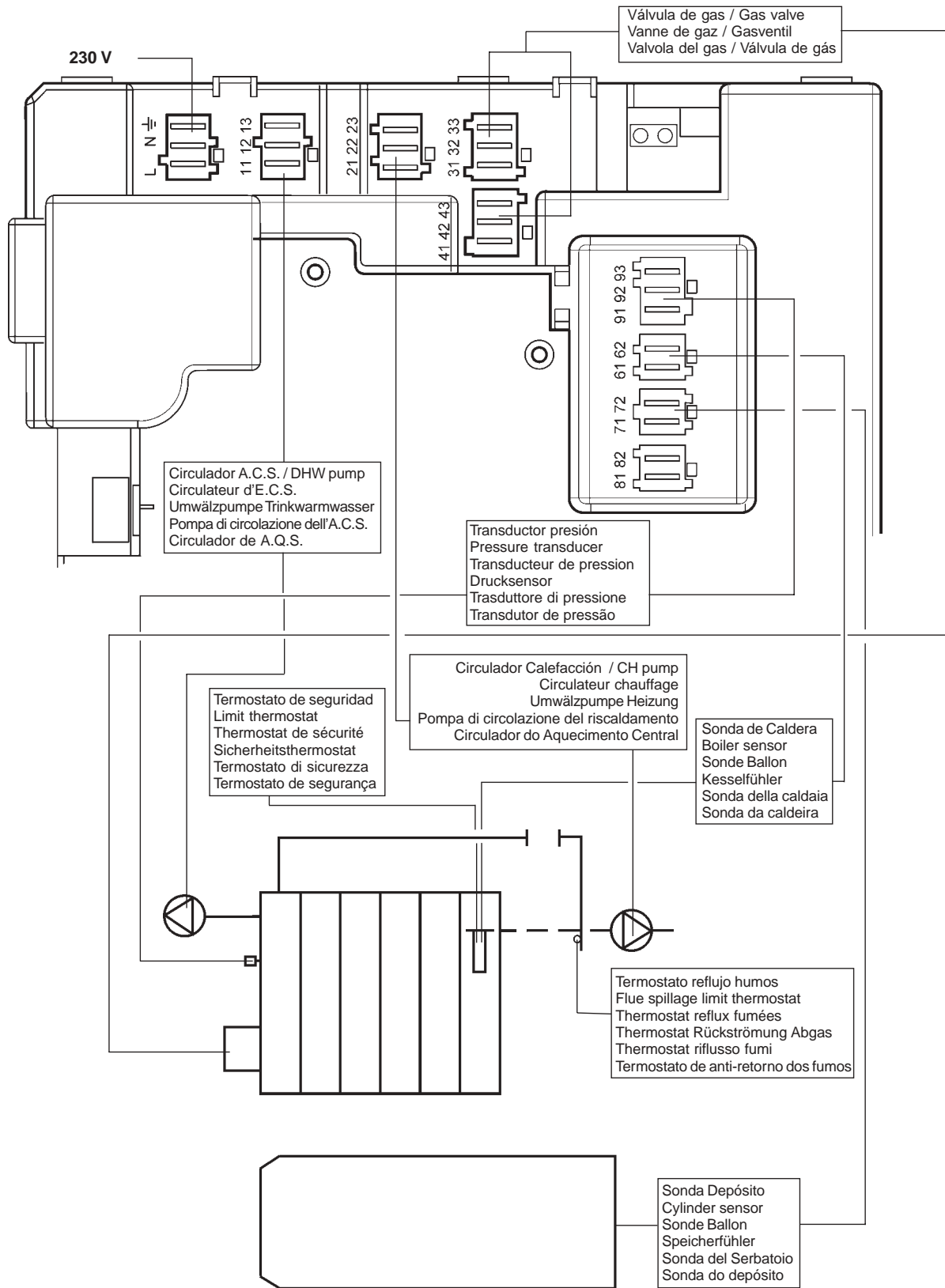

G 100 / GTA

**Características principales / Main features / Principales caractéristiques
Hauptmerkmale / Caratteristiche principali / Características principais**

Características eléctricas / Electrical data / Caractéristiques électriques / Elektrische Merkmale
Caratteristiche elettriche / Características eléctricas
220/230V ~ 50 Hz

	Potencia útil nominal Nominal Output Puissance nominale utile Nenn- Nutzleistung Potenza utile nominale Potência útil nominal		Rendimiento útil Net Efficiency Rendement utile Nutzungsgrad Resa utile Rendimento útil	Nº. de elementos No. of sections Nbre. éléments Anzahl der Heizelemente Nº di elementi Nº. de elementos	Nº de quemadores No. of burners Nbre. brûleurs Anzahl der Brenner Nº di bruciatori N.º de quemadores	
	kcal/h	kW	%		IE	XIE
G 100/30 IE-XIE	28.100	32,7	90,3	4	3	4
G 100/40 IE-XIE	38.200	44,4	90,5	5	3	4
G 100/50 IE-XIE	48.350	56,2	90,8	6	3	4
G 100/30 IE-XIE/GTA	28.100	32,7	90,3	4	3	4
G 100/40 IE-XIE/GTA	38.200	44,4	90,5	5	3	4

	Contenido de agua caldera Water Content Contenu d'eau chaudière Wasserinhalt Heizkessel Contenuto d'acqua della caldaia Conteúdo de água da caldeira	Peso aprox. Approx. Weight Poids approx. Gewicht ca. Peso approx. Peso aprox.	Pérdida carga circuito hidráulico caldera Waterside Pressure Drop Perte de charge circuit hydraulique chaudière Druckverlust Heizkreis Perdita di carico circuito idraulico caldaia Perda de carga no circuito hidráulico da caldeira (mm.c.a.) / (mm.w.g.) / (mm c.e.) / (m.W.S) (mm c.d'a.) / (mm.c.a.)		Tiro necesario en base chimenea Draught required at chimney base Tirage nécessaire à la base de la cheminée Notwendiger Zug an Schornsteinbasis Tiraggio necessario alla base della canna fumaria Tiragem necessária na base da chaminé
			$\Delta t=10\text{ }^{\circ}\text{C}$	$\Delta t=20\text{ }^{\circ}\text{C}$	(mm.c.a.) / (mm.w.g.) / (mm c.e.) (m.W.S) / (mm c.d'a.) / (mm.c.a.)
	(l)	(kg)			
G 100/30 IE-XIE	14,4	132	150	35	1,0
G 100/40 IE-XIE	18,0	161	275	70	1,0
G 100/50 IE-XIE	21,6	191	470	120	1,1
G 100/30 IE-XIE/GTA	19,0	262	150	35	1,0
G 100/40 IE-XIE/GTA	22,5	291	275	70	1,0

	Circulador Calefacción Modelo CH Pump Model Circulateur Chauffage Modèle Umwälzpumpe Heizung Modell Modello pompa di circolazione del Riscaldamento Circulador de Aquecimento Central Modelo	Circulador Sanitario Modelo DHW Pump Model Circulateur Sanitaire Modèle Umwälzpumpe Trinkwasser Modell Modello pompa di circolazione dell'a.c.s. Circulador Sanitário Modelo	Capacidad acumulador DHW Cylinder Capacity Capacité accumulateur Kapazität Speicher Capacità del serbatoio di accumulo Capacidade do acumulador (l)
G 100/30 IE-XIE	PC-1025	-	-
G 100/40 IE-XIE	PC-1025	-	-
G 100/50 IE-XIE	PC-1035	-	-
G 100/30 IE-XIE/GTA	PC-1025	NYL-43-15	120
G 100/40 IE-XIE/GTA	PC-1025	NYL-43-15	150

Presión de gas / Gas Inlet Pressure / Pression de gaz / Gasdruck / Pressione del gas / Pressão de gás (mbar)		
Natural / Natural Gas / Naturel Erdgas / Naturale / Natural	Propano / Propane Gas / Propane Propan / Propano / Propano	Butano / Butane Gas / Butane Butan / Butano / Butano
G 20 (20)	G 31 (37)	G 30 (28-30)

	Consumo / Gas Input Rate / Consommation / Verbrauch / Consumo in / Consumo m ³ (st)/h 15 °C – 1013 mbar		
	G 20	G 31	G 30
G 100/30 IE-XIE	3,83	1,47	1,12
G 100/40 IE-XIE	5,20	1,99	1,52
G 100/50 IE-XIE	6,55	2,51	1,91
G 100/30 IE-XIE/GTA	3,83	1,47	1,12
G 100/40 IE-XIE/GTA	5,20	1,99	1,52

Presión máxima de trabajo circuito calefacción: 4 bar.
 Presión máxima de trabajo circuito sanitario: 7 bar.
 Temperatura máxima de trabajo: 95 °C.
 Caudal específico G 100/30 GTA: 24,7 l/m para $\Delta t = 30$ K.
 Caudal específico G 100/40 GTA: 30 l/m para $\Delta t = 30$ K.

Max. working pressure of heating circuit: 4 bar
 Max. working pressure of DHW circuit: 7 bar
 Max. working temperature: 95 °C
 Specific flow rate of G 100/30 GTA boilers: 24.7 l/m for a $\Delta t = 30$ K
 Specific flow rate of G 100/40 GTA boilers: 30 l/m for a $\Delta t = 30$ K

Pression maximale de travail circuit chauffage: 4 bar
 Pression maximale de travail circuit sanitaire: 7 bar
 Température maximale de travail: 95 °C
 Débit spécifique G 100/30 GTA: 24,7 l/m pour $\Delta t = 30$ K.
 Débit spécifique G 100/40 GTA: 30 l/m pour $\Delta t = 30$ K.

Maximaler Betriebsdruck Heizkreis: 4 bar
 Maximaler Betriebsdruck Heißwasserkreis: 7 bar
 Maximale Betriebstemperatur: 95 °C
 Spezifischer Durchfluss G 100/30 GTA: 24,7 l/m für $\Delta t = 30$ K.
 Spezifischer Durchfluss G 100/40 GTA: 30 l/m für $\Delta t = 30$ K.

Pressione massima di esercizio del circuito di riscaldamento: 4 bar
 Pressione massima di esercizio del circuito dell'a.c.s.: 7 bar
 Temperatura massima di esercizio: 95 °C
 Portata specifica G100/30 GTA: 24,7 l/m per $\Delta t = 30$ K
 Portata specifica G100/40 GTA: 30 l/m per $\Delta t = 30$ K

Pressão máxima de trabalho no circuito de aquecimento central: 4 bar.
 Pressão máxima de trabalho no circuito sanitário: 7 bar.
 Temperatura máxima de trabalho: 95 °C
 Caudal específico G 100/30 GTA: 24,7 l/m para $\Delta t = 30$ K.
 Caudal específico G 100/40 GTA: 30 l/m para $\Delta t = 30$ K.

Dimensiones / Dimensions / Dimensions / Abmessungen / Dimensioni / Dimensões

G 100 CONFORT

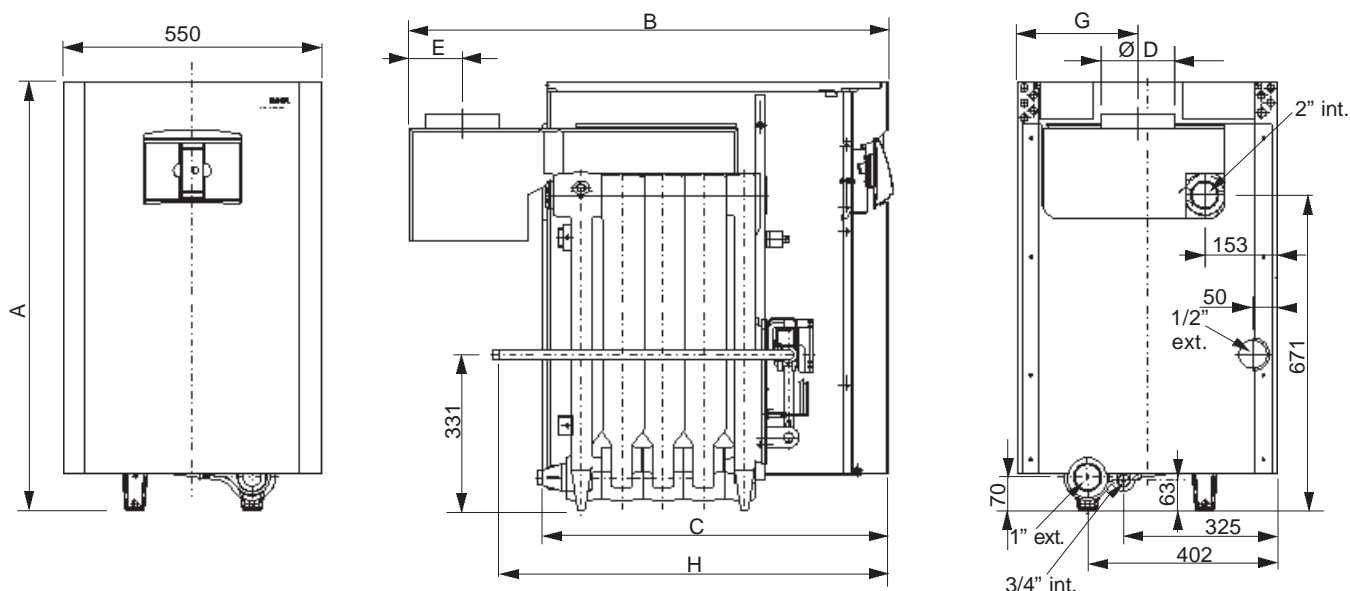

	A	B	C	* Ø D	E	G	H
G 100/30 CONFORT	911	913	648	155	113	255	748
G 100/40 CONFORT	911	1021	735	155	113	255	835
G 100/50 CONFORT	1014	1079	822	202	120	275	922

- * Ø D = Diámetro interior collarín (diámetro exterior máximo admisible en entronque chimenea).
- * Ø D = Inside diameter of flue socket collar (max. allowable OD of boiler flue duct connection)
- * Ø D = Diamètre intérieur collerette (diamètre extérieur maximal admissible dans embranchement cheminée)
- * Ø D = Innerer Flanschdurchmesser (Maximaler zulässiger äußerer Durchmesser am Schornsteinanschluss).
- * Ø D = Diametro interno collare (diametro esterno massimo permesso nell'innesto della canna fumaria)
- * Ø D = Diâmetro interior do colarinho (diâmetro exterior máximo admissível no entroncamento com a chaminé).

G 100 GTA CONFORT

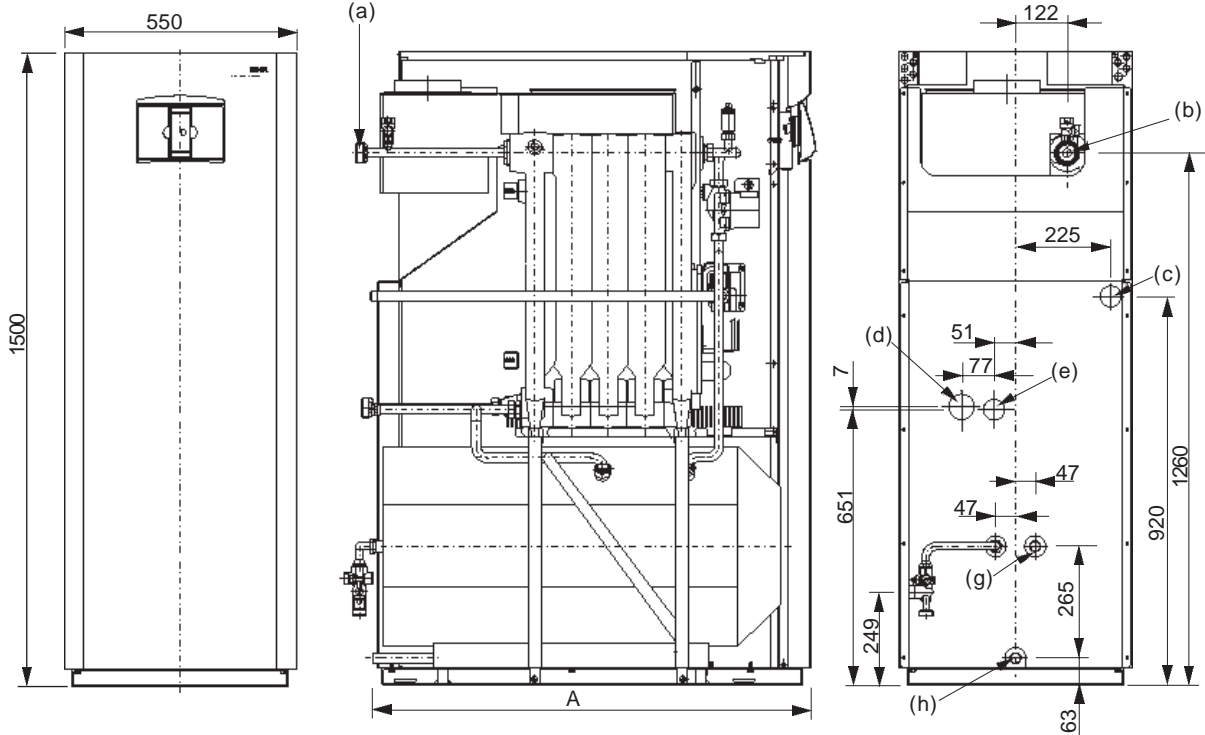

Caldera / Boiler Chaudière / Heizkessel Caldaia / Caldeira	Cotas / Dim. / Cotes Maße / Quota / Cotas "A"
G 100/30 GTA CONFORT	916
G 100/40 GTA CONFORT	1025

- (a): Ida Caldera 1" ext.
Boiler flow 1" (m)
Départ Chaudière
Vorlauf Heizung 1" außen
Mandata caldaia: 1" est.
Ida à caldeira 1" ext..
- (b): Válvula de seguridad 1/2" int.
Safety valve 1/2"
Soupape de sécurité
Sicherheitsventil 1/2" innen
Valvola di sicurezza: 1/2" int.
Válvula de segurança 1/2" int.
- (c): Tubo de gas 1/2" ext.
Gas connection 1/2"
Tuyau de gaz
Gasleitung 1/2" außen
Tubo del gas: 1/2" est.
Tubo de gás 1/2" ext.
- (d): Retorno caldera 1" ext.
Boiler return 1"
Retour chaudière
Rücklauf Kessel 1" außen
Ritorno caldaia: 1" est.
Retorno da caldeira 1" ext.
- (e): Vaciado caldera 1/2" ext.
Boiler drain 1/2"
Vidage chaudière
Kesselentleerung 1/2" außen
Svuotamento caldaia: 1/2" int.
Esvaziamento da caldeira 1/2" ext.
- (f): Entrada agua fría depósito 3/4" ext.
Cylinder cold water feed 3/4"
Entrée eau froide ballon
Eingang Kaltwasser Speicher 3/4" außen
Entrata acqua fredda serbatoio: 3/4" est.
Entrada de água fria no depósito 3/4" ext.
- (g): Salida agua caliente depósito 3/4" ext.
DHW draw-off 3/4" (m)
Sortie eau chaude ballon
Ausgang Heißwasser Speicher 3/4" außen
Uscita acqua calda serbatoio: 3/4" est.
Saída de água quente do depósito 3/4" ext
- (h): Vaciado depósito 3/4" ext.
DHW cylinder drain 3/4" (m)
Vidage ballon
Entleerung Speicher 3/4" außen
Svuotamento serbatoio: 3/4"
Esvaziamento do depósito 3/4" ext.

Curvas caudal - presión circuladores / Pump Performance Graphs
Courbes de débit - pression des circulateurs / Kurven Durchfluss - Pumpendruck
Curve portata/pressione delle pompe di circolazione / Curvas caudal - pressão dos circuladores

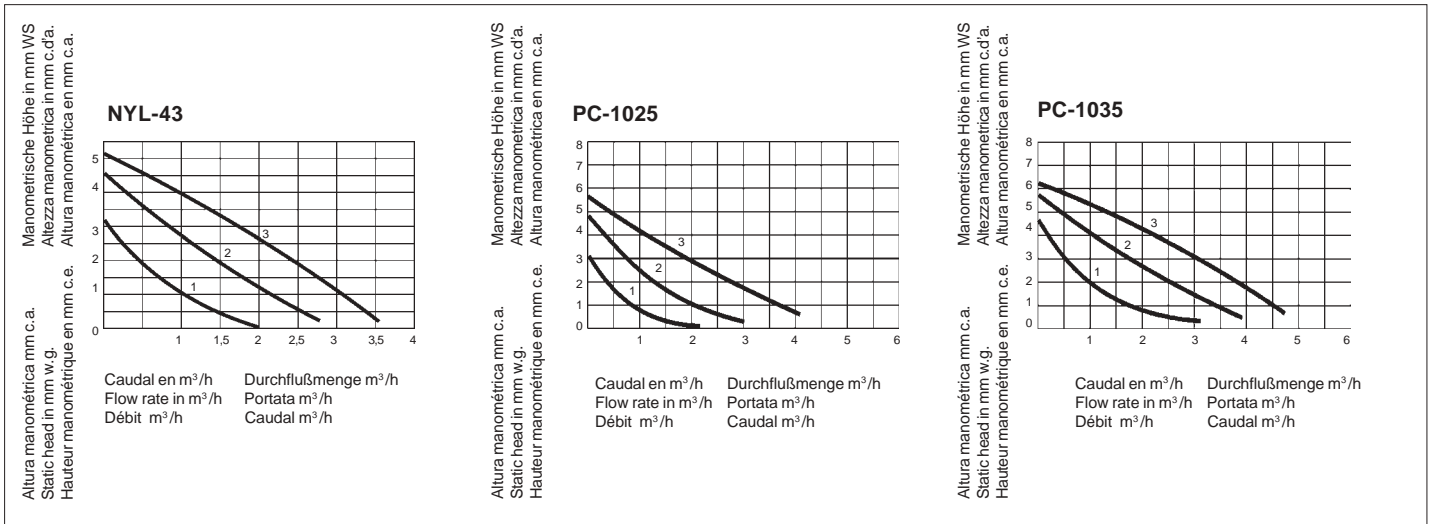

	Número y diámetro (mm) Inyector quemador Number of injectors and Size (mm) Nbre et diamètre (mm) injecteur brûleur Anzahl und Durchmesser (mm) Düsen Brenner Numero e diametro (mm) Iniettori bruciatore Número e diâmetro (mm) Injector do queimador		Diámetro diafragma (mm) Diaphragm Size (mm) Diamètre d iaphragme (mm) Durchmesser Membrane (mm) Diametro diaframma (mm) Diâmetro do diafragma (mm)
	Gas natural / Natural Gas Gaz naturel / Erdgas Gas naturale / Gás natural (G 20)	GLP / LPG / GPL Flüssiggas / GPL / GPL (G 30 / G 31)	GLP / LPG / GPL Flüssiggas / GPL / GPL (G 30 / G 31)
	G100/30 IE	3 x 2,95	3 x 1,82
G100/30 XIE	4 x 2,60	4 x 1,60	8,0
G100/40 IE	3 x 3,40	3 x 2,10	--
G100/40 XIE	4 x 3,00	4 x 1,82	--
G100/50 IE	3 x 3,80	3 x 2,35	10,3
G100/50 XIE	4 x 3,10	4 x 2,05	10,3
G100/30 IE GTA	3 x 2,95	3 x 1,82	8,0
G100/30 XIE GTA	4 x 2,60	4 x 1,60	8,0
G100/40 IE GTA	3 x 3,40	3 x 2,10	--
G100/40 XIE GTA	4 x 3,00	4 x 1,82	--

	Presión en inyectores / Burner Setting Pressure / Pression dans les injecteurs Düsendruck / Pressione negli iniettori / Pressão nos injectores (mbar)		
	G 20	G 30	G 31
G100/30 IE	11,0	26,3	33,6
G100/30 XIE	10,8	26,3	33,6
G100/40 IE	11,0	27,5	35,1
G100/40 XIE	10,8	27,3	34,8
G100/50 IE	12,4	26,02	33,2
G100/50 XIE	13,9	26,2	33,5
G100/30 IE GTA	11,0	26,3	33,6
G100/30 XIE GTA	10,8	26,3	33,6
G100/40 IE GTA	11,0	27,5	35,1
G100/40 XIE GTA	10,8	27,3	34,8

	Cantidad de aire mínima, en m ³ (n)/h / Minimum Airflow Rate m ³ (n)/h Quantité d'air minimal en mètres cubes (n)/h / Minimale Luftmenge in m ³ (n)/h Quantità minima d'aria (m ³ (n)/h) / Quantidade de ar mínima, em m ³ (n)/h		
	G 20	G 30	G 31
G 100/30 IE-XIE	44,94	42,65	42,99
G 100/40 IE-XIE	61,05	57,95	58,46
G 100/50 IE-XIE	76,88	72,83	73,61
G 100/30 IE-XIE GTA	44,94	42,65	42,99
G 100/40 IE-XIE GTA	61,05	57,95	58,46

	Volumen de humos en gr/s / Flue gas colume in gr/sec. / Volume de fumées, en g/sec. Rauchdurchsatz in gr/s / Volume di fumi in g/s. / Volume de fumos em gr/s.		
	G 20	G 30	G 31
G 100/30 IE-XIE	29,18	27,75	27,23
G 100/40 IE-XIE	39,63	37,70	37,03
G 100/50 IE-XIE	49,92	47,39	46,62
G 100/30 IE-XIE GTA	29,18	27,75	27,23
G 100/40 IE-XIE GTA	39,63	37,70	37,03

Transport and Delivery

VERY IMPORTANT: During handling operations and transport of G100 IE-XIE/GTA boilers, the boiler/cylinder assembly must necessarily be in a vertical position.

The G100 IE-XIE Confort and G100 IE-XIE/GTA Confort boilers are supplied in a single package, fully factory-assembled and internally wired.

They are suitably packed for transport on pallet and are duly protected with a plastic case and a cardboard cover. In addition, the G100 IE-XIE/GTA models are packed in a wooden crate.

The heating pump in its packing, inside the boiler casing and next to the gas valve.

The control panel bracket can be lowered to make access to the connector base easier.

Vitreous enamelled DHW cylinder with coil heat exchanger and sacrificial anode in GTA version boilers. In horizontal position under the boiler.

The pressure relief valve and the Flexbrane safety unit (GTA) are delivered in a plastic bag located near the Instructions brochure.

Installation

- Observe current regulations.
- Size and design the chimney in compliance with current local Regulations for Heating Systems in Buildings which apply.
- The installation should include a switch, a circuit breaker or other omnipolar disconnect switch to isolate all power supply lines to the boiler.
- Ensure there is a 230V-50Hz single-phase, earthed power point as well as a water supply and drain facility near the installation site of the unit.
- Connection of components external to the boiler shall be done using approved power cable - code designation H05 V₂ V₂-F1 105 °C (NOT supplied by Roca).
- In systems where a GTA version boiler has been installed, it is advisable to install an antithermosiphon valve in the "Heating flow" pipe in order to prevent the possibility of radiators warming up when there is no demand for heating.

Assembly

Location

As a rule, the location should be chosen according to conditions such as access of fuel, ventilation, flue gas removal, drain, etc.

The boiler should be installed at least 0.5 m away from any flammable material.

If there is a wooden, cork, or similar heat-sensitive floor, protect the supporting surface in a area of 0.5 m around the boiler with 20mm-thick (minimum) glass fibre.

- In the case of GTA version boilers, put the wooden pallet near the final location of the appliance and turn the boiler/cylinder assembly around 90° while still on the pallet until its sides form a right angle with one of the longest sides of the wooden pallet.
- Tilt the boiler until it partly rests on the floor on its front or rear side; then remove the pallet from the base of the boiler/cylinder assembly and rest the latter totally on the floor.
- Always check that the boiler/cylinder assembly is level on its final location and that there is sufficient clearance from surrounding walls to permit future maintenance operations.

Hydraulic Connection to the System

- In boilers with heating service only, fit the pressure relief valve provided and make the connection to the Flow and Return circuits through the connections (1) and (2). Figure 1.

- With these boilers, install the specific safety devices for sealed system installations, as shown in Figure 2. The size of all safety pipes shall comply with current regulations.
- Optionally remove the plug from the tapping (3) and fit a drain cock in its place. Figure 1.
- In GTA version boilers, fit the pressure relief valve (4) and the Flexbrane safety unit (5), route them to a drain and make the connection to the Heating Flow and Return circuits through the connections (6) and (7). Pipe the cylinder to the cold water mains and the DHW system through (8) and (9) respectively. Figures 3 and 4.
- With these boilers, install the same safety devices mentioned above for the heating only version boilers. Here too, all safety pipes shall be sized in compliance with current regulations.
- Optionally remove the plug from the tapping (10) and fit a drain cock in its place. Figure 4.

Watertight Test

- With GTA version boilers, **fill the DHW cylinder first and then the heating circuit with water** (in heating only boilers, this circuit) until the fill pressure on the "bar" scale in the CCE control panel reaches the correct reading according to the system static head (1 bar = 10 metres).
- Check the hydraulic circuit(s) for leaks.

Electrical Connection and to the Flue Stack

- Make the electrical connection of the heating pump using the cable (11) that passes through a 1/4 turn cable clamp located at the top rear side of the right-hand casing panel. Figures 1 and 3.
 - Remove the front casing panel by pulling from its top side until the snap-on locating pins disengage from their slots (12) in the control panel bracket. Then, through its lower part, lift it and detach it from the studs (13) in the side casing panels. Figures 5 and 7 (G100) or 6 and 8 (G100/GTA).
 - Remove the 2 screws that fasten the rear part of the top cover (14) to the side casing panels, slide it backwards until the lower front tabs (15) disengage from their slots (16) in the side panels. Lift it and remove it. Figure 9.
 - Loosen slightly the upper screws (17) that secure the control panel bracket to the side casing panels and tilt it forward together with the panel itself. Figures 5 and 6.
 - Pass the power cable* (NOT supplied by Roca) for connection to the mains through the cable clamp located at the top rear side of the right-hand casing panel. In the pre-punched cable entry knock-out (18) fit a cable clamp for passing the wire of an optional room thermostat, carry them to the control panel and wire them there as directed in the Instructions that come with the CCE panels. Figures 1 and 3.
- * Use approved power supply cable - code designation H05 V₂ V₂-F1 105 °C.
- Replace the control panel bracket, the top cover and the front casing panel.
 - Connect the flue duct to the boiler through the flue socket collar (19) and ensure that the connection is air-tight with pipe jointer material (rope seal), ceramic fibre gasket or putty that does not set hard. Figures 1 and 3.

Connecting to the gas supply



- Connect the mains gas supply line to the boiler stub-out (20) and check its leak soundness with soapy water. Figures 1 and 3.

Location of Electrical Connections and Sensors





Figures 10 (G100) and 11 (G100/GTA).

Checking Limit Thermostat Operation

It is advisable to carry out this check in order to prevent future serious malfunction. This can only be done if no lockout condition exists, that is, under fault code 00 (see "Fault Code" section in the Instructions for the Control Panel) or because of a lockout (code 11) caused by a fault in the limit thermostat itself.

- With the Boiler Control Service Selector key (7), select . Fig. 9.
- Press the **bar** key. The pressure scale shows the current system pressure.
- Press the **+** and **-** keys at a time. The screen will flash 5 times before displaying code 00 only, if no lockout condition exists; in case of lockout, the code corresponding to the fault that caused it will be displayed.
- Stop pressing the **+** and **-** keys.
- Press the **+** key and, without releasing it, press the  key. The screen will flash twice before showing the expanded temperature scale from 40 °C to 140 °C, with the segment in line with 114 °C flashing slowly.

Should the checking function have started already, with the boiler temperature below 80°C, the burner will fire and the pump will be OFF. The unit will establish its setpoint temperature at 114°C.

- 1 – If the limit thermostat trips before the boiler reaches 114 °C, it means that it is working correctly. In this case the burner will not operate but the pump will.
 - The screen will alternate displaying code 04 (limit thermostat tripped) and the 40–140 °C scale. No service indication will be displayed on the screen above.
 - Press the **-** and  keys at a time. The screen will flash and then display code 04 only.
 - Stop pressing the **-** and  keys.
 - Press the **+** and **-** keys simultaneously. The screen will flash twice before displaying the current pressure on the **bar** scale. The top display screen will show .
 - Stop pressing the **+** and **-** keys.
 - Wait until the boiler temperature drops below 80 °C and reset the limit thermostat. The  LED will go out.
- 2 – If the limit thermostat does not trip before the boiler reaches 114 °C, it means that it is not working properly. In this case, the burner will not run but the pump will.
 - The screen will alternate displaying code 11 and the expanded 40 °C – 140 °C temperature scale.
 - Replace the faulty thermostat with a new one and check its operation in accordance with the procedure described in this chapter.

Magnesium Anode Status Indicator (GTA version boilers)

To fit this optional control device to monitor the wearing of the cylinder anode, proceed as directed in the Instructions that come with it.

Operation

Procedure prior to the first lighting

- Ensure that the heating system Flow and Return valves (if any) are open.
- Connect the boiler to the power supply line and check that the control panel is under voltage. The "power on"  LED (21) will light up green. Figures 12 (G100) and 13 (G100/GTA). In case of malfunction, please refer to the "Fault Codes" section in the Instructions for

CCE control panels and proceed accordingly. Whenever necessary, call Roca's nearest Service Centre.



- Read carefully the information contained in the Instructions mentioned above.
- Bleed the air from the installation and radiators and, if necessary, top up with water until the fill pressure on the **bar** scale in the control panel reaches the required level (1 bar = 10 metres).
- Vent the gas train by loosening the pressure test point screw (22) at the gas valve inlet. Figure 14.
- With GTA version boilers, check that the plug on the Flexvent automatic floatvent (23) is slack. Figure 15.
- Check that the cold water inlet cock (black wheel) in the Flexbrane safety unit (5) is open. Figure 3.
- Open a hot water tap to bleed the air in the circuit.
- Check that the boiler parameters and those for the installation (service, temperatures, etc.) have been properly selected and set in accordance with the Instructions for CCE control panels.
- Open the boiler gas service cock.

First Lighting

- Check the pump(s) for correct operation and unlock them, if necessary, by pressing a screwdriver into the slot on the shaft-end and, at the same time, turn it.
- Check the burners for correct operation.
- Check that there are no flue gas leaks and that radiators reach the required temperature.



Central Heating Service Only (NOT in GTA version boilers)

During demand for heating:

- The  symbol flashes slowly.
- The burner runs until the boiler temperature matches the factory-set value, i.e. 60 °C. Refer to the "Changing the Setpoints" section in the Instructions supplied with the control panel.
- The pump runs as long as the boiler temperature is higher than the programmed "Min. Heat. Temp." and stops working when its value drops 7 °C below the "Min. Heat. Temp.". When demand for heating stops:
 - The  symbol remains steady.
 - The burner if OFF.
 - The pump runs as long as the boiler temperature is equal to or lower than the "Min. Heat. Temp." or 2 minutes after burner shutdown.





Domestic Hot Water Service Only (GTA version boilers)

The  symbol in the top display window is permanently ON.

- 1 – With no production of Domestic Hot Water ("no Domestic Hot Water" programme or with the cylinder water hot already):
 - The  symbol in the display window is permanently ON.
 - The burner and pumps do not operate; but they do for maintenance.
- 2 – With Domestic Hot Water production ("Domestic Hot Water" programme or with the cylinder water not yet hot):
 - The  symbol flashes slowly. Production of domestic hot water begins when the cylinder water temperature drops 2 °C below the set value (the factory setting is 70 °C) and stops when the cylinder water reaches the setpoint temperature.
 - The boiler water is self-regulating to reach 80 °C.



The DHW pump will only run the first time provided the boiler water temperature is higher than that in the DHW cylinder +5 °C and the boiler temperature is higher than the "Min. Heat. Temp."



Combined Central Heating and DHW Service (GTA version boilers)

Both the  and  symbols are displayed. When the unit starts operating, the water in the boiler is cold. The  symbol flashes and the  symbol is permanently ON.

During demand for Domestic Hot Water, operation will be as described in the previous section under "Domestic Hot Water Service Only".

When demand for Domestic Hot Water stops (but not for Heating):

- The  symbol will flash slowly, but not the  symbol.
- The burner will run until the boiler temperature reaches the setpoint value for Heating. The Heating pump will start running when the boiler temperature rises above the "Min. Heat. Temp." and will stop running when the boiler temperature drops 7 °C below the "Min. Heat. Temp."

When demand for Heating ends, the  and  symbols will stop flashing. The burner will stop running, but the DHW pump will continue to run for one minute or until the boiler water temperature drops below the "Min. Heat. Temp.". At this point, the Heating pump will stop running.

Checking the Condition of the Sacrificial Anode (GTA boilers)

Proceed according to the Instructions that are delivered with it. **If the pointer reaches the red area when the button is pressed, replace the spent anode immediately.**

Changing the Type of Gas

It must be carried out by a qualified professional. This can be:

- 1 – From Natural Gas to LPG
 - 2 – From LPG to Natural Gas
- Cut off the power and gas supplies to the boiler.
 - Remove the front casing cover as directed under "Electrical Connection".
 - Remove the 3-4 injectors (24) from the burner holder manifold using a 22AF spanner and replace them with the appropriate ones for the new gas, as shown in the table "Number of Injectors and Size" in the "Main Features" section. Fig. 14.
 - From natural gas to LPG, Remove the bolts that secure the flange (25), tighten the pressure regulator screw firmly and fit the diaphragm suitable for the new gas.
 - From LPG to natural gas, Remove the bolts that secure the flange (25), remove the diaphragm and adjust the pressure regulator according to the "Gas Pressure" table in the Technical Features section.
 - Reassemble in reverse order.
 - Carry out a test for gas-tightness with soapy water.
 - Stick the label corresponding to the new gas on the burner holder manifold.

Important Recommendations

- If the boiler is located in a frost-risk area, some anti-freeze product should be added to the water in proportion to the minimum outside air temperature of the place.
- We recommend that the properties of the water in the system be as follows:
 - pH: 7.5 - 8.5
 - Hardness: 8 - 12 French degrees*

* One French degree is equivalent to 1 gram of calcium carbonate per 100 litres of water.

- Should it become necessary to add water to the system, wait until the boiler is completely cold before doing so.

These boilers are fitted with a safety system that operates based on the improper removal of flue gases, thus causing the gas valve to close. Once the fault condition has been cleared, it can be reset by pressing on “RESET” (26). Figure 16.

Only parts supplied by the manufacturer can be used to replace faulty ones.

Should the boiler lock out repeatedly, the flue gas removal problem must be solved by adopting the appropriate measures.

Carry out a run test following any operation, change or adjustment.

- Limiting the noise level in the system.

Should the risk of nuisance noise level exist, the following steps can be adopted:

- Insulate the pump.
- Insulate the boiler, if necessary.
- Lay the pipes with vibration isolation stays/ mounts.
- Re-size the pipes.
- Limit the number of elbows and non-insulated built-in pipes.

Note:

Specifications and performance qualities are subject to change without notice.

CE Marked

The G100 IE-XIE Confort and G100 IE-XIE/GTA Confort boilers are certified to comply with the essential requirements of the Electromagnetic Compatibility Directive 89/336/EEC, the Gas Appliances Directive 90/396/EEC, the Low Voltage Directive 73/23/EEC, and the Energy Efficiency Directive 92/42/EEC, and are therefore permitted to carry the CE mark.

ROCA

Baxi Roca Calefacción, S.L.
Salvador Espriu, 9
08908 L'Hospitalet de Llobregat
BARCELONA
Teléfono 93 263 0009
Telefax 93 263 4633
www.baxi-roca.com
A BAXI GR●UP company

